

GEARex® FR and DR All-steel gear couplings

Single-cardanic, high power density

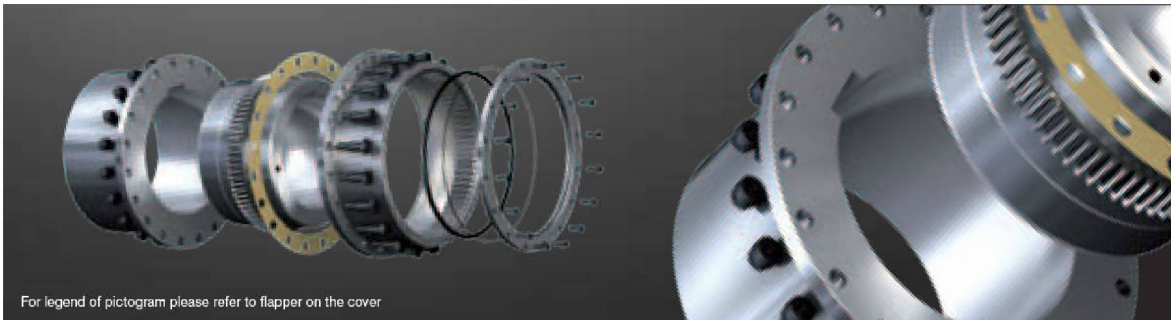

For legend of pictogram please refer to flapper on the cover

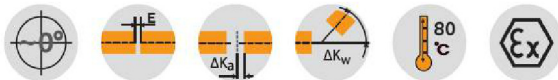

Dimensions																		
Size	Torque [Nm]		Maximum finish bore		Dimensions [mm]										Dowel screw (10.9)			Grease feeding [dm ³]
	T _{KN}	T _{KN} (42CrMo4)	d ₁	d ₄	l ₁ , l ₂	Lengthened hub max. l ₁ , l ₂	D	DA ₁	DA ₂	D _F	L _R	F ¹⁾	d ₃ ¹⁾	z	M	T _A [Nm]		
10	930	1580	50	60	43	105	67	111	84	84	88	74	52	6	M6	15	0,02	
15	2000	3300	64	78	50	115	87	152	107	107	103	84	68	8	M8	36	0,04	
20	3500	6300	80	95	62	130	108	178	130	130	127	104	85	6	M10	72	0,08	
25	6500	11000	98	115	76	150	130	213	158	158	157	123	110	6	M12	125	0,12	
30	10000	17400	112	135	90	170	153	240	182	182	185	148	130	8	M12	125	0,18	
35	17000	28800	133	155	105	185	180	280	214	214	216	172	150	8	M14	200	0,22	
40	28500	48500	158	185	120	215	214	318	250	250	244	192	175	8	M14	200	0,35	
45	37000	62000	172	200	135	245	233	347	274	274	276	216	190	10	M14	200	0,45	
50	51000	86000	192	225	150	295	260	390	309	309	305	241	220	8	M18	430	0,70	
55	65000	110000	210	245	175	300	283	425,5	334	334	356	275	250	14	M18	430	0,90	
60	85000	145000	232	265	190	305	312	457	365,5	365,5	386	316	265	14	M18	430	1,15	
70	135000	240000	276	310	220	310	371	527	425	425	450	360	300	16	M20	610	1,50	
80	175000	300000	300	340	280	-	394	545	475	462	570	340	310	18	M20	610	2,50	
85	225000	380000	325	370	292	-	430	585	515	500	597	352	330	20	M20	610	3,00	
90	290000	500000	350	400	305	-	464	640	560	546	623	365	360	20	M24	1000	4,00	
100	380000	650000	390	440	330	-	512	690	612	594	673	390	400	24	M24	1000	5,00	
110	480000	820000	420	480	350	-	560	765	665	647	710	410	420	20	M30	1700	6,00	
120	620000	1050000	450	520	420	-	608	825	720	700	852	480	470	24	M30	1700	7,50	
130	-	1450000	500	560	440	-	684	950	805	760	890	520	520	20	M36	2800	9,00	
140	-	1950000	550	610	460	-	750	1020	875	835	930	570	590	24	M36	2800	12,00	
150	-	2750000	630	690	520	-	850	1140	975	935	1055	630	670	30	M36	2800	15,00	

■ = Standard

¹⁾ Space required to align the coupling or replace the sealing ring

Ordering example:	GEARex® FR 10	d ₁ Ø50	d ₄ Ø60
	Size and type of coupling	Finish bore with keyway to DIN 6885 sheet 1	Finish bore with keyway to DIN 6885 sheet 1

Components

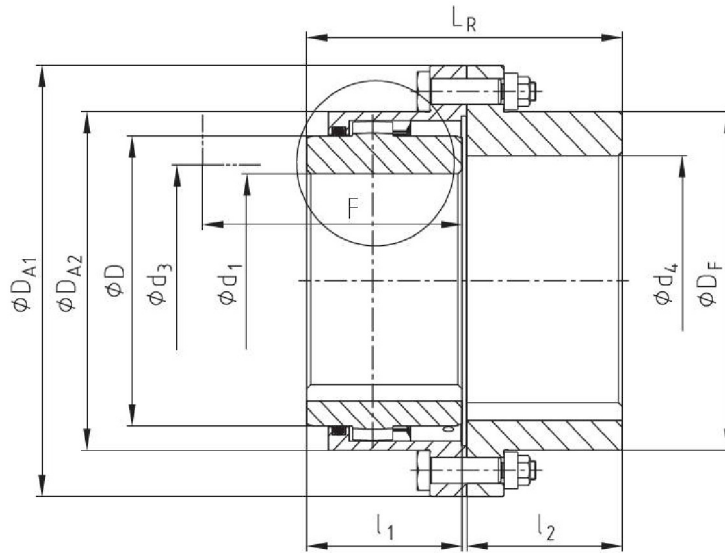

Types

Type FR

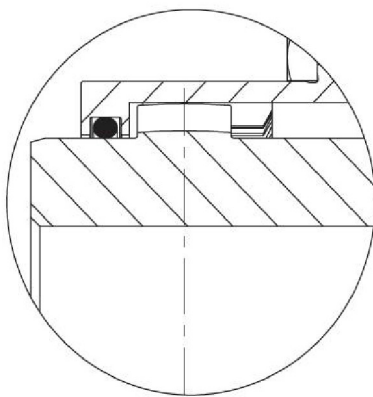

Type DR

